



Modeling and Analysis of ± 400 KV HVDC Static Circuit Breaker Performance

Islam M. Abdelqawee*

Faculty of Engineering at Shoubra,
Electrical Engineering Department,
Benha University,
Cairo, Egypt.

I. Abdulmoniem

Faculty of Engineering at Shoubra,
Electrical Engineering Department,
Benha University,
Cairo, Egypt.

M. A. Abd-Allah

Faculty of Engineering at Shoubra,
Electrical Engineering Department,
Benha University,
Cairo, Egypt.

Abstract: High voltage direct current (HVDC) networks are effective keys for the incorporation of considerable scale of distributed resources with the utility power networks. This fast progress of HVDC power networks give rise to the increasing interest for finding an efficient and reliable HVDC circuit breaker. The rapid proceed in electronic switches, specially the insulated gate bipolar transistor (IGBT), allow to be vastly applied in the evolution of a quite efficient static circuit breaker. This work suggest a ± 400 kV static HVDC circuit breaker using IGBT. The suggested circuit breaker is applied and validated for a hypothetical wind generation station and transported via submarine cables to the power network. The breaker was validated to a network voltage up to ± 400 kV bipolar system and a rated power up to 360 MW. In the suggested breaker, two series of IGBTs were used. This breaker proof that it has a fast disconnecting capability, reliable and efficiency. A resistancecapacitance freewheeling diodes is used to suppress the overvoltage during the period of fault. The efficiency of the proposed breaker is proofed by a comparison its performance of the two different SSCB topologies. The comparison was established on the surge-voltage, the over-current suppression arising from short circuit current interruption and reconnection of semiconductor devices.

Keywords: HVDC circuit breaker, IGBT, short circuit, safe operating area, hybrid optimization.

Received: 15 January 2023; **Accepted:** 25 March 2023; **Published:** 30 May 2023

I. INTRODUCTION

In early decades, HVDC transmission networks were applied as a connection between remote electrical power sources, e.g. renewable resources and utility grid, long distances of submarine cables, and for connection of power networks having different power frequencies. Early, point-to-point technology for HVDC bulk transmission of electrical power is the well-established technology.

With the speedy increase of renewable energy resources applications worldwide, it has become necessary to increase the investment in electrical energy transmission capacity. The HVDC network could facilitate the incorporation of solar and wind to decrease noticeably the carbon emissions [1]; [2]; [3]; [4]; [5]; [6]. In point-to-point HVDC systems, if a fault happened at the DC side, the converters control the fault current to zero, or this fault is cleared by the AC direction circuit breaker.

*Correspondence concerning this article should be addressed to Islam M. Abdelqawee, Faculty of Engineering at Shoubra, Electrical Engineering Department, Benha University, Cairo, Egypt. E-mail: Islam.ahmed@feg.bu.edu.eg

Recently, the great enhancement in the devices of power electronics, rating, technology and performance, helps in the rapid growing of using HVDC networks and increase the possibility to form multi-terminal HVDC systems. With increasing the HVDC networks lengths worldwide, fast, efficient and reliable HVDC circuit breakers must be developed to disconnect the faulty equipment quickly and safely to maintain the preserve the HVDC system [7]; [8].

HVDC circuit breakers were classified into three categories; mechanical, solid-state, and hybrid circuit breakers [9]. Sulphur hexafluoride (SF6) breaker is greatly used, as a mechanical switch. The action of the mechanical breakers is not resilient and its breaking time is too long (tens of milliseconds) to meet the requirement of fast fault current interruption, so they cannot clear short-circuit faults rapidly [10]; [11]; [12]. The HVDC hybrid type circuit breakers are capable to disconnect the fault current during a few milliseconds. On the other hand, the size of the hybrid type is large and complex. The capital cost of the hybrid type is higher than the mechanical type, particularly for interconnected grids [13]. For higher voltage ratings, hybrid type has limitations in handling with large fault currents [14]. Solid-state circuit breaker proven an accurate, flexible and fast circuit breaker, accordingly and keep the line voltage to an acceptable range [15]. They are greatly used as main technology in HVDC power networks [16]. The switching overvoltage and over currents of semiconductor devices are the confrontation problems faced the several researchers in the application of static circuit breakers. The converter equipment faced a problem with increasing the HVDC network withstand voltage and the overall system cost will be very high [17].

IGBTs are excessively applied as switches in electrical power applications for blocking voltages in the range 400V to 6.5kV. The main implementations in control circuit of motors, renewable energy resources, uninterruptible power supplies, etc. A continuous development in IGBT technology, from the first generation of IGBT in 1980 until now, resulting in widely applications of this static switch [18]; [19]; [20]; [21]. The recent versions have lower static and switching of power losses, and superior rudeness concerning overcurrent and short circuit

failures.

This paper introduces a proposed and surge-less SSCB in an MMC-HVDC transmission system. In this work, two series of IGBTs are utilized to preserve the high voltage of the power network. This suggested circuit breaker has a steady disconnecting capability, which enable to quickly cut-off and prevent damages to power network components.

Resistancecapacitance freewheeling diodes were utilized instead of metal oxide varistors in the suggested scheme to mitigate the voltage surges and clear any residual charge. At the same time, they attenuate greatly the risk of overvoltage during the period of fault. An auxiliary circuit is used in mechanical CB to achieve the zero cross point, while this circuit is not needed with the suggested breaker. To prove the efficiency of the suggested breaker a comparison with two SSCB topologies namely, the LC resonance semiconductor DC breaker and the static DC circuit breaker using a freewheeling diode. The comparison is established on the following parameters, the surge-voltage, the over-current suppression arising from interruption of fault current and reconnection of semiconductor devices, respectively.

II. SYSTEM DESCRIPTION

The fundamental aim of this work is to develop a static HVDC circuit breaker qualified as EHVDC circuit breaker has fast, reliable and safe characteristics. The suggested circuit breaker is utilized in the connection between large offshore wind farm and a utility grid. The offshore wind farm rating is 360 MW, linked with the utility grid via 40 km HVDC submarine cable. The HVDC submarine cable is operated at ± 400 kV, with a nominal current of 450A. The cross-sectional area of the submarine cable is 150 mm² according to IEC60228 with respect to the rated specified current. The short-circuit current up to 6 kA approximately. The IGBT safe operating area at a short circuit (SCSOA) used is up to 7kA and the safe operation area at a reverse bias (RBSOA) is up to 2kA.

The typical values of the system and the specifications of the different components used in the suggested static HVDC circuit breaker are given in table (1).

TABLE 1
SYSTEM COMPONENT DESCRIPTION

Component	Description
IGBT Module	CM1000HG-130XA
Transmission line length/H	40 km - 0.5 mh/km
Total dc resistance of cable $0.7667\Omega/\text{km}$	30.668Ω
Total inductance	20 mH
Total capacitance of $0.13 \mu\text{F}/\text{km}$	$5.2 \mu\text{F}$
I_C	1000A
SCSOA	7KA
RBSOA	2KA
V_{CES}	6500V

In the proposed static circuit breaker, 250 IGBT switches were used in series and parallel to be adequate with the ± 400 kV system voltage. Moreover, in order to attenuate the conduction losses and to improve the current handling performance of the switching valve, two IGBT branches are utilized to handle the circuit rated operating current, which is 450 A, and activate safe mode in reverse bias operating area. The values of the electric parameter are designed based on hybrid optimization methodology, namely JPSOBAT algorithm, which refer to jellyfish/Particle swarm/Bat algorithms [20]. This algorithm technique has target of improving and fast solution stability based on collection of swarm, jellyfish and bat algorithm, respectively with few numbers of iteration compared to other techniques. The integration time absolute error (ITAE) is applied as an objective function to

select the optimal values of the IGBT voltage as [20].

$$\text{ITAE} = \int_0^{\infty} t|e(t)| \cdot dt \dots\dots(1)$$

Where, e the error that can be estimated from:

$$\text{Error signal (e)} = V_{\text{ref}} - V_{\text{CEvmeasured}} \dots\dots\dots(2)$$

With constraints for IGBT module [22]:

$$I_{S,C} \leq 6k \cdot A \quad \text{and} \quad V_{CE} < 4kV \dots\dots\dots(3)$$

Performance curves of IGBT CM1000HG-130XA is illustrated in Fig. (1), which prove the reason for selecting the groups of connecting the IGBTs in series and parallel connection, all given data about IGBT mentioned in high power switching device with Mitsubishi electric corporation [22]. From Fig. 1(a), the maximum collector-emitter voltage should not be above 4.5 kV with a current of collector 2kA. At these values, the short circuit current of the IGBT will be less than 6 kA.

A. Performance curve of IGBT

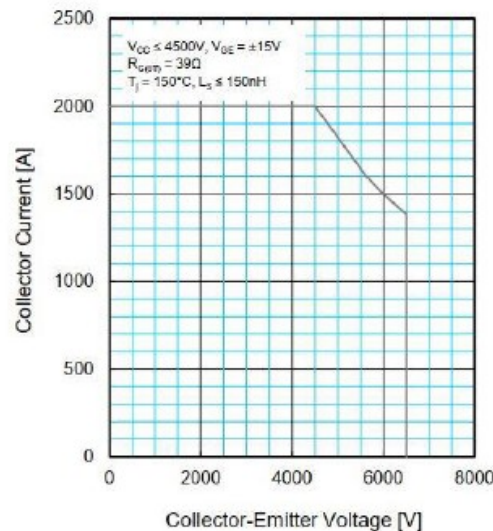

Fig. 1. Reverse bias safe operating area (RBSOA).

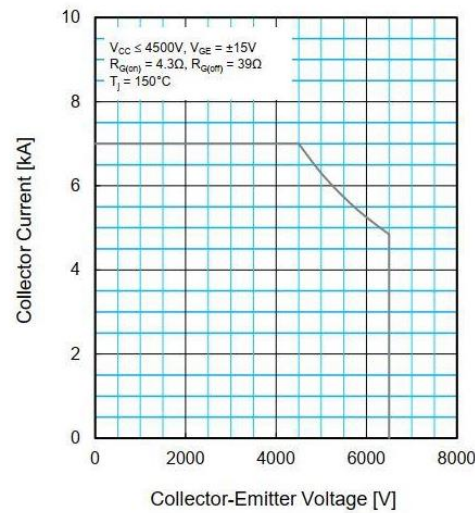

Fig. 2. Short circuit safe operation area (SCSOA)

III. PROPOSED TOPOLOGY OF CIRCUIT BREAKER

The challenges in the high-voltage DC current circuit breakers design are dependent on creating a zero-crossing point for the instantaneous current at the instant of the fault, and control the variation of current (di/dt) at fault occurred. To overcome this problem, a circuit dependent on creating an electrical resonance frequency at the fault instant is established. The second challenge is how to absorb the energy stored in the system resulted from the rapid increase in current, at the instant of disconnecting the fault current by the breaker; where there is a large amount of stored energy in system may lead to the destruction of the system. One of the approved systems to overcome this is supporting with using an inductance, which is connected to the circuit breaker at the moment of the trip.

Figure 3 illustrates the proposed circuit breaker between a large wind power plant and a load. Voltage source converter (Vdc) which deliver the energy to the load through a submarine long cable represents the wind power plant. The circuit breaker supported with the following electrical devices, the IGBT (S1), the power diode (D1), the mutual inductances (L1 and L2), and finally the snubber circuit and the energy absorption which are consisting of (R1, R2, C1 and C2). On the right side, the total inductance of both the transmission line and the load is represented by (L3). The DC resistance of the submarine power cable is represented by (R3), and RL is represented the load resistance. The system is tested and analyzed under normal operation, fault conditions with rapidly increase of current. At the fault time, the load will isolated by the circuit breaker [23]. The simulation model of the proposed system is shown in Fig. 4.

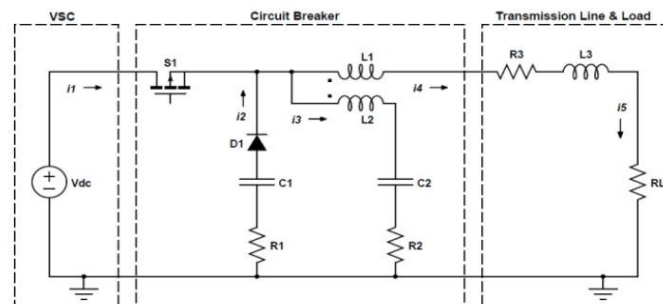

Fig. 3. The equivalent circuit of the proposed system [23]

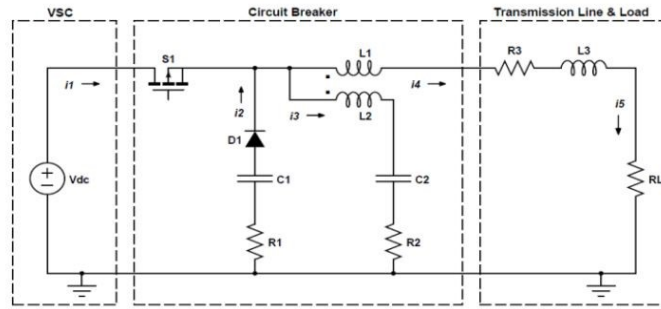

Fig. 4. Simulation model with JPSOBAT algorithm

A. Normal Operation

In the proposed circuit, the IGBT is assumed an ideal, i.e., the current passing through the IGBT is the same as the primary current of the load in the normal operation state, the supply source is smooth, i.e. free from ripples, and there is no current passes through the secondary branch represented by D1, C1, R1, C2 and R2. In practice, the IGBT is a group of valves connected together to comply with the required operating voltage of the system, the nominal current of the system, and the withstand short circuit current. In this case, the current drawn from the wind power plant (i_1) is equal to;

$$i_1 = i_2 + i_3 + i_4 \dots (4)$$

B. Fault Occurrence

When a fault occurred at $t = t_1$, the main current start to rise up to the short circuit level value, where breaker is required to disconnect this short circuit current. The voltage V_{dc} is supposed to be constant from fault occurred to fault cleared. The current rise can be calculated as follows;

$$\Delta i_1 / (t_2 - t_1) = V_{dc} / (L_2 + L_3) \dots (5)$$

Where;

t_1 is the time of fault occur

t_2 is the time of fault clear

The rise of current varied the flux, which arises an inductance L_2 . The induced current namely i_3 will opposes the change in its initiating current i_4 . The current i_1 will increase until the breaker disconnect the source.

C. Fault Isolation with Disconnect Load.

When the current reach the value of maximum fault current at t_2 , the IGBT switch off consequently source disconnect from load and HVDC link. Branch consist of C2, R2, L2 is created to steer the energy in case of fault to ground. When the IGBT switched off, the rise in value of d_i/d_t , which have effect in destructive reverse voltage, may be damage the solid state valve, to overcome

potential reverse voltage and limit it. Therefore, another branch with D1, C1 and R1 is created instead of metal oxide varistor (MOV). Formula used for mutual inductance as follow:

$$v_1 = L_1 \frac{di_1}{dt} + M \frac{di_2}{dt} \dots (6)$$

$$v_2 = L_2 \frac{di_2}{dt} + M \frac{di_1}{dt} \dots (7)$$

$$M = \sqrt{L_1 L_2} \dots (8)$$

Where M is the mutual inductance. Sum of inductance is considered as L, where;

$$L = L_1 + L_3 \dots (9)$$

Total stored energy in lump of system can be calculated from:

$$W = \frac{L i_{sc}^2}{2} \dots (10)$$

IV. SIMULATION RESULTS AND DISCUSSION

As illustrate in Fig. 5, the main current (i_m) in normal operation reach up to 450 A. when fault occurred at time equal to one second, the threshold short circuit value reaches to 2.5 kA. Therefore, the static valve (IGBT) will switch off and disconnect the source, duration time to detect and disconnect almost 2mS. In Fig. 6, there is no current through RCD branch but when fault occurred the current will appear thorough RCD branch where it reaches to -2.4 kA. The main object of this branch is to protect IGBTs from destructed voltage when it switch off.

Figure 7 shows the voltage cross solid state circuit breaker which clear it is to neglect voltage drop through normal operation but when fault occurred it appear and reach up to about 500kv, it is consider in design of solid state modular circuit breaker. The power losses in the solid state in normal operation is very small, in the proposed model reach to 170 W, as shown in Fig. 8, which can be neglected when fault occurred the maximum instantaneous power losses reach to about 6 kW. Although the value of the instantaneous power losses is very high at the short circuit, but the average power losses will equal 300 W.

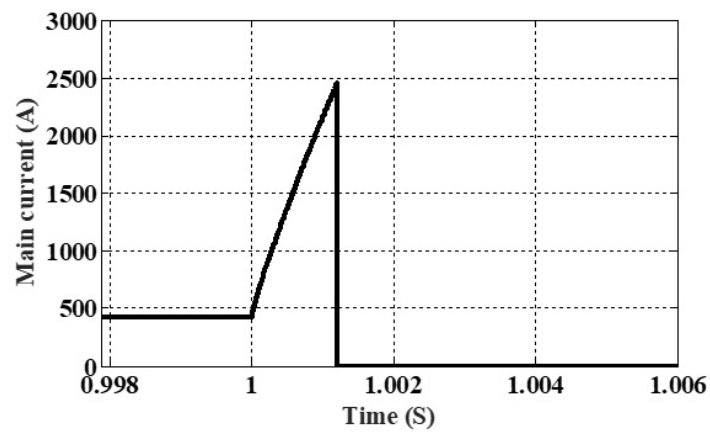

Fig. 5. Main current in normal operation

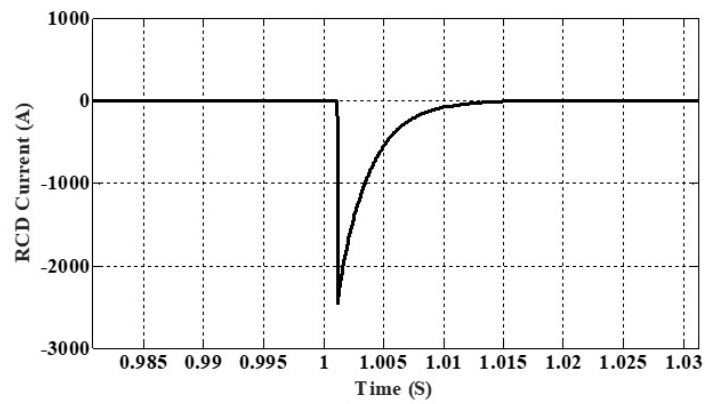

Fig. 6. The current through RCD branch

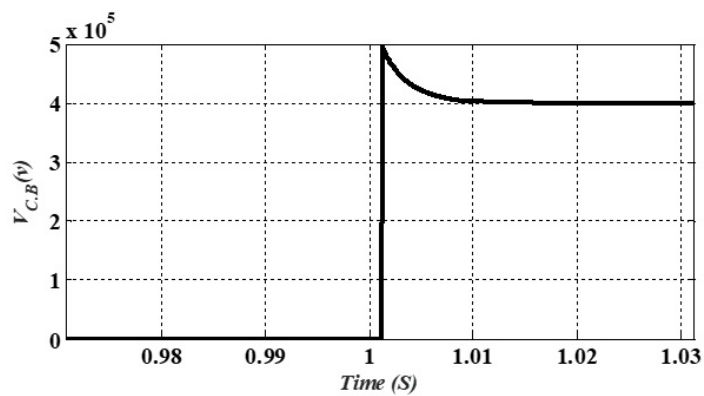

Fig. 7. Voltage through IGBT C.B.

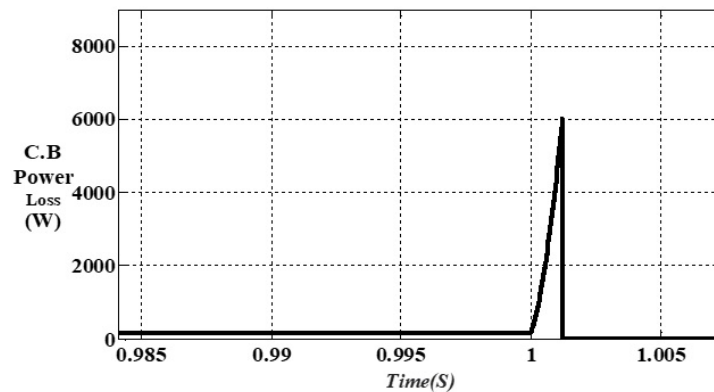

Fig. 8. The power losses in the IGBT C.B.

V. CONCLUSION

The proposed static high voltage circuit breaker illustrates a reliable and efficient high voltage direct current circuit breaker design. Fast time to switch of the source around 3 ms to separate it from fault no vacuum or sf6 circuit breaker .by using JPSOBAT algorithm we safe IGBT module with applicable sizing of snubber branch and mutual branch from destructive voltage with 250 IGBT switches in series and parallel to be adequate with the 400 kV system voltage, power up to 360 MW. Moreover, in order to reduce the conduction losses and improve current handling performance of the switching valve, two IGBT branches are utilized to handle the rated operating current of the circuit. Remote wind and solar farms transfer power to the grid by direct current submarine long cables, tens of kilometers long such a scenario. In the proposed circuit breaker which does not include mechanical breakers, no high-voltage zinc oxide surge arresters, it may be a future-proof, cost-effective and maintenance solution for medium range and large scale of wind and solar farms.

REFERENCES

- [1] M. Barnes, D. S. Vilchis-Rodriguez, X. Pei, R. Shuttleworth, O. Cwikowski, and A. C. Smith, "Hvdc circuit breakers—a review," *IEEE Access*, vol. 8, pp. 211 829–211 848, 2020.
- [2] G. A. Ludin, M. A. Amin, H. Matayoshi, S. S. Rangarajan, A. M. Hemeida, H. Takahashi, and T. Senjyu, "Solid-state dc circuit breakers and their comparison in modular multilevel converter based-hvdc transmission system," *Electronics*, vol. 10, no. 10, p. 1204, 2021.
- [3] C. M. Franck, "Hvdc circuit breakers: A review identifying future research needs," *IEEE transactions on power delivery*, vol. 26, no. 2, pp. 998–1007, 2011.
- [4] W. Xiang, Y. Hua, J. Wen, M. Yao, and N. Li, "Research on fast solid state dc breaker based on a natural current zero-crossing point," *Journal of Modern Power Systems and Clean Energy*, vol. 2, no. 1, pp. 30–38, 2014.
- [5] I. I. Hussein, S. Essallah, and A. Khedher, "The impact of hvdc on the current and future energy markets," *International Journal of Electrical and Electronic Engineering & Telecommunications*, vol. 11, no. 6, 2022.
- [6] Y. Du, J. Deng, H. Lin, H. Zheng, K. Xiang, and Y. Shen, "Research and experiment of a current-limiting hvdc circuit breaker," *The Journal of Engineering*, vol. 2019, no. 16, pp. 2002–2006, 2019.
- [7] O. Cwikowski, B. Chang, M. Barnes, R. Shuttleworth, and A. Beddard, "Fault current testing envelopes for vsc hvdc circuit breakers," *IET Generation, Transmission & Distribution*, vol. 10, no. 6, pp. 1393–1400, 2016.
- [8] M. K. Bucher and C. M. Franck, "Fault current interruption in multiterminal hvdc networks," *IEEE Transactions on Power Delivery*, vol. 31, no. 1, pp. 87–95, 2015.
- [9] E. Taherzadeh, H. Radmanesh, S. Javadi, and G. Gharehpetian, "Circuit breakers in hvdc systems: state-of-the-art review and future trends," *Protection and Control of Modern Power Systems*, vol. 8, no. 3, pp. 1–16, 2023.
- [10] K. Tahata, S. El Oukaili, K. Kamei, D. Yoshida, Y. Kono, R. Yamamoto, and H. Ito, "Hvdc circuit breakers for hvdc grid applications," in *11th IET international conference on AC and DC power transmission*. IET, 2015, pp. 1–9.
- [11] R. Sander, M. Suriyah, and T. Leibfried, "Characterization of a countercurrent injection-based hvdc circuit breaker," *IEEE Transactions on Power Electronics*, vol. 33, no. 4, pp. 2948–2956, 2017.

- [12] A. Virdag, T. Hager, and R. W. De Doncker, "Performance analysis of counter-current injection based dc circuit breaker with improved capacitor charging circuit," in *2019 21st European Conference on Power Electronics and Applications (EPE'19 ECCE Europe)*. IEEE, 2019, pp. P-1.
- [13] M. Ahmad and Z. Wang, "A hybrid dc circuit breaker with fault-current-limiting capability for vsc-hvdc transmission system," *Energies*, vol. 12, no. 12, p. 2388, 2019.
- [14] L. Angquist, S. Norrga, T. Modeer, and S. Nee, "Fast hvdc breaker using reduced-rating power electronics," 2017.
- [15] L. Zhu, Y. Zheng *et al.*, "The study on new solid-state breaker and its over-voltage suppression technique," *Energy and Power Engineering*, vol. 5, no. 04, p. 1249, 2013.
- [16] C. Ding, T. Nie, X. Tian, T. Chen, and Z. Yuan, "Analysis of the influence of rc buffer on dc solid-state circuit breaker," *Energy Reports*, vol. 6, pp. 1483-1489, 2020.
- [17] N. Iwamuro and T. Laska, "Igbt history, state-of-the-art, and future prospects," *IEEE Transactions on Electron Devices*, vol. 64, no. 3, pp. 741-752, 2017.
- [18] M. T. A. Rahimo, A. Kopta, U. Schlapbach, J. Vobecký, R. Schnell, and S. Klaka, "The bi-mode insulated gate transistor (bigt) a potential technology for higher power applications," *2009 21st International Symposium on Power Semiconductor Devices & IC's*, pp. 283-286, 2009.
- [19] F. Niedernostheide, H. Schulze, and T. Laska, "Igbts: recent developments and future perspectives," in *Proc. Int. Seminar on Power Semiconductors*, 2016, pp. 40-50.
- [20] I. M. Abdelqawee, A. W. Emam, M. S. ElBages, and M. A. Ebrahim, "An improved energy management strategy for fuel cell/battery/supercapacitor system using a novel hybrid jellyfish/particle swarm/bat optimizers," *Journal of Energy Storage*, vol. 57, p. 106276, 2023.
- [21] L. Mackey, C. Peng, and I. Husain, "Progressive switching of hybrid dc circuit breakers for faster fault isolation," in *2018 IEEE Energy Conversion Congress and Exposition (ECCE)*. IEEE, 2018, pp. 7150-7157.
- [22] M. Electric. (2023) High voltage insulated gate bipolar transistor. [Online]. Available: <https://shorturl.at/osIOZ>
- [23] S. Negari, "A new design of solid state circuit breaker for hvdc applications," 2021.