

Key Knowledge Generation

Publication details, including instructions for author and
Subscription information:

<http://kkgpublications.com/technology/>

A Roof Top Utility Interfaced PV Power System for Rural India

S. N. SINGH ¹, V. S. PRATHIBA ², RAJ RANJAN SINGH ³, S. R. LENKA ⁴

^{1,2,3}National Institute of Technology Jamshedpur, India

⁴Jan Shikhan Sansthan Jamshedpur, India

Published online: 29 February 2016

To cite this article: S. N. Singh, V. S. Prathiba, R. R. Singh and S. R. Lenka, “A roof top utility interfaced PV power system for rural India,” *International Journal of Technology and Engineering Studies*, vol. 2, no. 1, pp. 13-18, 2016.

DOI: <https://dx.doi.org/10.20469/ijtes.2.40003-1>

To link to this article: <http://kkgpublications.com/wp-content/uploads/2016/2/Volume2/IJTES-40003-1.pdf>

PLEASE SCROLL DOWN FOR ARTICLE

KKG Publications makes every effort to ascertain the precision of all the information (the “Content”) contained in the publications on our platform. However, KKG Publications, our agents, and our licensors make no representations or warranties whatsoever as to the accuracy, completeness, or suitability for any purpose of the content. All opinions and views stated in this publication are not endorsed by KKG Publications. These are purely the opinions and views of authors. The accuracy of the content should not be relied upon and primary sources of information should be considered for any verification. KKG Publications shall not be liable for any costs, expenses, proceedings, loss, actions, demands, damages, expenses and other liabilities directly or indirectly caused in connection with given content.

This article may be utilized for research, edifying, and private study purposes. Any substantial or systematic reproduction, redistribution, reselling, loan, sub-licensing, systematic supply, or distribution in any form to anyone is expressly verboten.

A ROOF TOP UTILITY INTERFACED PV POWER SYSTEM FOR RURAL INDIA

S. N. SINGH ^{1*}, V. S. PRATHIBA ², RAJ RANJAN SINGH ³, S. R. LENKA ⁴

^{1,2,3}National Institute of Technology Jamshedpur, India

⁴Jan Shikhan Sansthan Jamshedpur, India

Keywords:

Photovoltaic (PV)
Pulse Width Modulation (PWM)
Total Harmonic Distortion (THD)

Received: 17 October 2015

Accepted: 02 December 2015

Published: 29 February 2016

Abstract. In this paper, a Hybrid solar PV-AC Grid power supply system for 220V, PWM AC, 50Hz, 1kW has been developed. India is facing an acute shortage of electricity, especially in remote areas of rural sectors, due to shrinking conventional grid supply. As a result, the system needs to be integrated with other non-conventional sources like solar energy. The proposed PV system consists of a photovoltaic array, bidirectional PWM converter (THD <5-15%), and intelligent controller. The controller works so that the maximum solar energy stored in Battery is utilized for a particular predetermined load, and the remaining power is drawn from the AC grid. As placed on the rooftop of a house, the PV module does not require extra land or any additional expensive structure. The Green AC power generated through converter from solar panels is given preference over grid power such that the sum of two powers is equal to the required total average load, i.e., 4kWh per day. This has resulted in a grid power saving up to 50% or even more and created a good impact in rural society by generating sustainable (24x7days) power to rural houses for domestic and wage/self-employment among potential youth.

INTRODUCTION

Electricity is the basic need of all living beings. The supply of electricity from conventional grid (utility) is shrinking due to the depletion of raw material such as fossil fuel etc. Thus the conventional grid expansion especially in rural sector has become almost standstill. Integration of conventional grid power source with renewable solar energy source seems to be feasible and an optimal solution, as in this Hybrid solar PV-AC Grid power supply system load power is shared among both the energy sources i.e., conventional as well as non-conventional sources, meeting the demand of the user in a cost effective way. Attempts were made by Scientist and Engineers to develop such hybrid power supply systems in a centralized manner in the past but the system could not be implemented due to its complexity and costly affair. A smart distributed micro grid model has been proposed to overcome the same and prototype system module for rural house, consuming approximately 129kWh energy for 30 days, has been developed. The result has been found an encouraging one with a saving of more than 50% power from grid supply.

Micro Smart Grid Network Model of a System

A smart micro grid, as proposed, is integration of renewable solar energy as primary source with conventional grid sharing power with it. The use of wired/wireless

communications technology keep tracking on availability of grid power and load demand as per requirement of a rural house and thus balances both the power sources in an automated fashion to provide a sustainable power supply to these rural houses. Electronic power conditioning unit, control of PV power generation from primary source as well as the distribution of electricity sharing with grid is important aspects of the smart grid.

The system model comprises of centralized grid power source distributed at power hubs (nodes) connected in ring network topology with local power generation sources (which comprises of Bi-directional Power Converter, Micro-controller) communication network devices etc. The load below 500W is normally powered by primary PV Power source, where as in case of peak load i.e. 1kW, sustainability of power across load is maintained by the secondary conventional power grid sources. The excess power, if generated by local PV power sources is stored in storage device i.e., Battery/ or super capacitor and draw the same from it, whenever is needed [1], [2], [3], [4], [5], [6], [7]. In this innovative project work, a roof top utility interfaced solar PV system delivering 129KWh energy over a period of 30days has been developed to supply sustainable power to a rural house. A simulation study has been carried out to explore the possibility of implementation of such network model in grid connected remote area of Indian villages.

* Corresponding author: S.N.Singh
E-mail: snsingh.ece@nitjsr.ac.in; vsprathiba2013@gmail.com

Smart Grid Model

The proposed smart grid model for Rural India is given below in Figure 1.

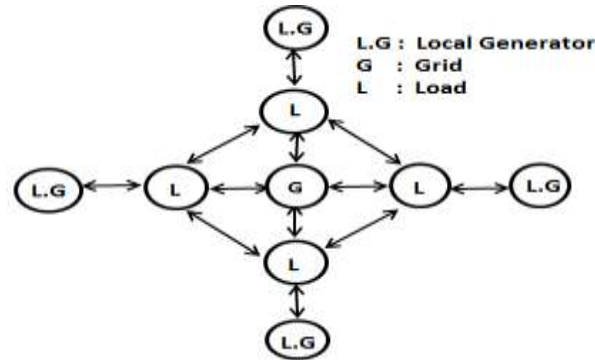

Fig. 1. Proposed micro smart grid network model for rural India

Control Algorithm

The control action in smart grid network system is performed by controller through intelligent program. The load demand is balanced with supply in sharing mode to generate a sustainable power supply 24x7 days in these rural houses. The algorithm reflects the operation in the following steps:

- System collects data from the status of main grid, PV micro grid and load which are internally connected.
- Algorithm is activated and Load is switched over to primary or secondary power sources as per the status of load demand and availability of strength of power sources.
- In case of peak load, the load is shared with grid in sharing mode or shifted to other period on existence of low demand.

The process is repeated and initiated again at an interval as received on change of demand of Load.

PV System Model

The PV hybrid system comprises of the following module:

- PV Module 7x100 Wp
- Battery 2x150 Ah
- Bidirectional Power Converter 1kW
- Load Matrix (1kW)

The hybrid system model has been reflected in Figure 2

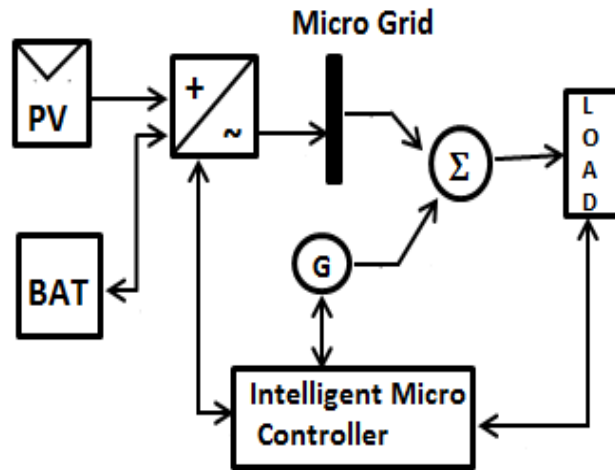

Fig. 2. Block diagram of PV system model

A prototype PV power module integrating with grid/DG power sources, as proposed, has been developed [6] and installed in laboratory as per computed load energy requirement of rural house, taken over a period of 30 days, located in the outskirts remote area of Jamshedpur city (India). The primary source of

power supply to these houses is the PV power stored in the battery. Load power is managed either by battery backed up PV system or supplementary integrated grid/DG as secondary source.

The Power Converter of PV system converts the DC Power obtained from PV modules into Pulse Width Modulation

(PWM) load waveform, and on averaging, it produces SPWM AC power 220V AC, 50Hz 1KW output with the help of a Transistorized centre tapped Transformer (Tr) based Push-Pull configured BJT/ MOSFET/ IGBT Bi-directional Power Converter circuit (Figure3). The electronic control block will consist of Base /gate drive circuit using opt-coupler device and

digital Micro-controller. This provides flexibility with the circuit design without hardware modifications, making it a favorable choice for Application Specific Integrated Circuit (ASIC) prototyping.

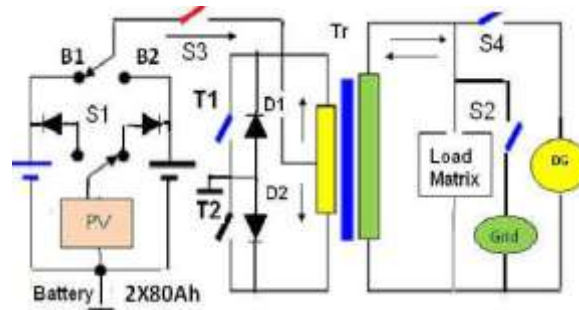

Fig. 3. System model power converter circuit

The system is designed for a rural home as per load energy requirement with the specifications as given below:

- Load Energy = 129kWh Watt-hours over a period of 30 days
- PV size = 7 x 100 Wp, 12 V
- Battery Size = 2 x 150 Ah, 12V low self discharge inverter grade tubular lead acid battery.
- Load(s) = CFL lamps, Fans, TV and Pump etc.
- Converter = Bi-directional 1kW, 12 DC ~ 220 V SPWM AC, 50 Hz (Distortion 5- 15%)
- Grid/DG Set = Grid distributed network/Portable LPG 2x550VA/Diesel or Kerosene oil based 1.5 KVA.

- Controller unit = Intelligent micro-controller producing SPWM control pulses for sharing power with grid in time sharing mode of its operation.

Design of PV-Grid Hybrid Power System

Power consumption of a typical rural house of a cluster in a remote area near Jamshedpur City (India) of village is computed [8], [9]. The average power requirement on per day basis, considering Loads as TV, light /Fan and pump/electrical equipment etc. and the same has been reflected in Table 1. The load profile varies from month to month as per demand at user end. The PV modules are fitted on roof of each house and generate DC power during sun hour period.

TABLE 1
POWER CONSUMPTION AT MAXIMUM LOAD

Electrical Appliance	Power(watts)	Time(hr)	Energy(watt-hr)
Light/Fan	8X20W	10hr	1600W-hr
TV/Computer	100W	4.5hr	450W-hr
Pump etc	750kW	3hr	2250W-hr
Total	1kW	17.5hr	4300W-hr

Energy consumption for 30 days = 4300 W-hr * 30 days =129 kw-hr

PV Sizing

The PV size is computed considering the sun hour, i.e., light falling on surface of PV module, as 6 hours (9AM-3 PM) and its efficiency of power system conversion as 90%.

No. of PV Module (100Wp) =
 $(\text{Energy consumption (W-h)} / (100\text{Wp} * 6\text{hr})) = 7$ (1)

Battery Sizing

The battery store the electrical energy converted by PV module during the sun hour period

Battery sizing:

Energy consumption/ (Battery voltage (12V)*150Ah)
 i.e., $4300\text{W-h} / (150 * 12\text{V}) = 2.4$ (2)Bi-

Directional Converter

In the inverter mode, the Converter unit converts 12V DC voltage into usable SPWM AC Voltage 220V, 50V 50Hz. To deliver a peak load of 1kW, the Inverter is designed to sustain up to this load. The Inverter has been designed as a bi-directional converter which charges the battery bank of 2*150 Ah also.

DG Set

In case of grid failure, the power is drawn from DG set. It must sustain the peak load of 500VA / 1.5 KVA.

RESULTS AND DISCUSSION

Load Power Management

The power delivery to load(s) is governed by the adaptive energy balance equation:

$$i.e., PLOAD = PGRID /DG + PV BATTERY \quad (3)$$

The consistency in load power (PLOAD) delivery is obtained due to integration of input power sources i.e. PV module stored energy in Battery PVBAT and grid Power (PGRID).

The stability analysis of the PV system has been conducted under varying load as well as amount of insolation. The results were found consistent. The load energy profile (i.e., load power consumption per day on an average basis of a rural house under one cluster unit), has been shown in the Figure 4.

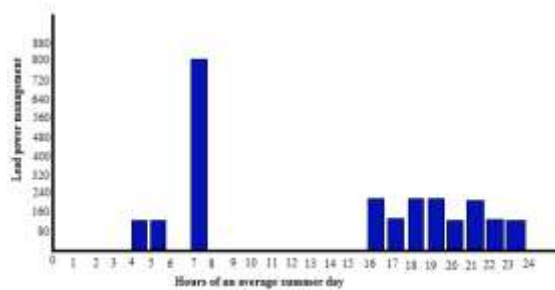

Fig. 4. Load power consumption of a typical day

Power Saving

The average approximated power delivered by the PV system and shared with Grid during each month in the year 2014 is reflected in Table 2

Payback Period

The system feasibility and cost has been evaluated. It has been observed that the cost of Electricity, initially found as high value, reduces with time and found that the payback period falls within 3-5 years only.

TABLE 2

POWER SHARING (APPROX) BETWEEN MICRO-GRID (PV SYSTEM) AND (GRID/DG) AT MAXIMUM LOAD ENERGY OVER A PERIOD OF 30 DAYS I.E 129KWH

Month	Power from PV Grid in kWh	Power from Grid/DGin kWh	Month	Power from PV Grid in kWh	Power from Grid/DGin kWh
Jan'14	90	39	July'14	55	74
Feb'14	102	27	Aug'14	73	56
Mar'14	108	21	Sep'14	74	55
Apr'14	94	35	Oct'14	78	51
May'14	84	45	Nov'14	76	53
June'14	74	55	Dec'14	61	68

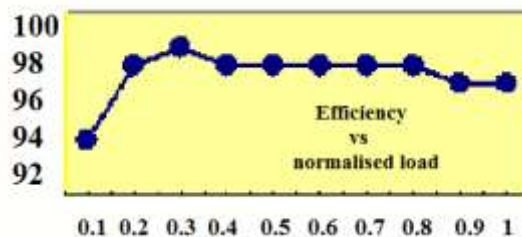

Fig. 5. Plot of efficiency (in %) Vs Load (in %) of PV converter system

Socio Economic Impact on Rural Society

The study of a literacy centre running in a rural house reveals that availability of power from the grid was observed as very poor ranging from 6-10 hours only. During its frequent

failure or load shedding period, k.oil fed Petromax lamp were being used for lighting in these houses which were causing inconvenience to potential youth and women clientele group trainee/ learners, continuing their study/training leading to unsafe

environment. This could become possible with the use of proposed solar integrated grid power source provided to these rural houses. An example of spreading vocational literacy through these houses is reflected in Figure 6.

The impact of sustainable power to these houses from the integrated sources could be able to bring many benefits and summarized as follows:

- Approximately 30-40% potential youth were trained in income generating vocational skill formation courses in solar powered schools/community centers.
- Female illiterate and neo-literate beneficiary specially belonging to socially and economically backward society were

trained intrades e.g. cottage industry products (candle, agarbatti, masala, pickle, jam-jelly and papad making etc).

- They could start the production of agro-based products like vermi compost and Mushroom, garment/bag making, Jute product (like Bag, wall hanging) items, Handicraft items, Photo frames, Interior home decorative items, Soft toys making etc.
- School dropout children, along with their mother started going to literacy schools and thus literacy rate could be increased from 30% to 60%.
- Villagers could be able to engage themselves in production of cottage industry products during evening hours. Thus economic status of these rural masses increased by 30%.



Fig. 6. Vocational literacy training for self employment run by solar electrified rural houses

CONCLUSION AND RECOMMENDATIONS

India has a large land area with an average solar energy of 5kWh/m² per day over 280 clear days. Even if 1% of this land is used to harness solar energy at an over all efficiency of 10% as much as 429x10⁹ kWh/per year of electricity can be generated. Indian power grid is always overburdened due to gap between power generation and load consumption. The smart micro grid Network model of 1kW capacity has been developed for rural houses. The individual roof mounted hybrid PV-AC system, as proposed can work as a standalone unit also at places where Grid connectivity is very poor. The system offers various other features like: less maintenance, high efficiency, simple solar conversion technology, generation of pollution free green electricity etc. The system can find its applications in many areas of rural sectors of Indian villages for supplying power for:

- Lighting, Pumps used for irrigation or drinking water supply,
- Running schools/ Community Centers for children as well as for adults
- Shops, clinics, nursing homes and dispensary, weekly Sunday market,
- Cottage industry equipment etc.

The experimental results prove that the proposed micro grid PV system can reduce the energy consumption drastically to an extent of 50% or more and give a reliable support to the Grid. But the technology still has shortcomings such as high initial installation cost and low energy-conversion efficiency 15%, thus requiring continuous improvements of both PV cell and power inverter technologies. The impact on rural society in spreading literacy for skill development and generating wage/self employment was found with excellent result.

Declaration of Conflicting Interests

There are neither financial nor non-financial conflicts involved.

Acknowledgement

We acknowledge with thanks to Head Department of Electronics and Communication Engineering National Institute of Technology Jamshedpur - An Institution of National Importance under Ministry of HRD, Govt of India to help in carrying out the Project work.

REFERENCES

- [1] S. N. Singh and A. K. Singh, "Design and development of grid-assisted adaptive solar (PV) power converter for water-pumping system in Indian villages," *Journal of ARISE*. 2009.
- [2] S. N. Singh, P. Singh and S. K. Swati, "Rural home energy management by fuzzy control model for autonomous solar (PV)-diesel power system in India," *IJAEST*, vol. 4, no. 1, pp. 15-21, 2011.
- [3] S. Singh and N. Snehlata, "Intelligent home energy management by fuzzy adaptive control model for solar (PV)-grid/DG power system in India," *International Journal of Power, Control, Signal & Computation*, vol. 2, no. 2, pp. 60-65, 2011.
- [4] S. N. Singh and A. K. Singh, "Optimal design of a cost effective solar home power system-an alternative solution to DG for grid deprived rural India," *International Journal of Research and Reviews in Applied Sciences*, vol. 2, no. 1, pp. 60-66, 2010.
- [5] S. N. Singh, A. K. Singh, S. K. Swati and R. Jha, "Rural home energy management by fuzzy control model for utility interfaced autonomous solar (PV)-DG power system in India," *IJAEST*, vol. 14, no. 1, pp.15-21, 2012.
- [6] H. Saha, A. Mondal, A. Mahato and K. Mukhopadhyay, "Grid-interfaced urban domestic power pack," in *Photovoltaic Specialists Conference, 2002. Conference Record of the Twenty-Ninth IEEE*, pp. 1625-1629, May, 2002.
- [7] K. Kurokawa, "PV systems in urban environment," *Solar Energy Materials and Solar Cells*, vol. 67, no. 1, pp. 469-479, 2001.
- [8] S. N. Singh and A. K. Singh, "Modeling and dynamics of a PWM sinusoidal Inverter for water pumping system for use in agriculture and household application," *Journal of IEEMA Jan*, pp. 114-122, 2008.
- [9] S. N. Singh, "Design of fuzzy controller for sustainable utility-DG interfaced solar powered rural Indian literacy houses," *International Journal of Advanced Engineering Research and Studies*, vol. 1, no. 2, pp. 26-30, 2012.
- [10] F. Engels, and A. V. Münch, "The micro smart grid as a materialised imaginary within the German energy transition." *Energy Research & Social Science*, vol. 9, pp.35-42, 2015.

— This article does not have any appendix. —